



SL-P6R1-WF SL-PA6R1-WF

Single Stack Light Monitoring Module with Wi-Fi Interface

Features

- Able to detect the status of each color segment: ON, OFF, or Flashing
- 6-channel DC/AC Digital Input and 1-channel alarm Relay Output
- Compatible with the IEEE802.11b/g/n standards
- Support infrastructure and limit-AP modes for wireless networks
- Status monitoring for user-defined combinations of multiple color segments
- Reports the duration of the previous and current status
- Supports the Modbus RTU, Modbus TCP and MQTT protocols
- Includes RS-485/Ethernet/Wi-Fi communication interfaces
- Includes redundant power inputs: PoE (IEEE 802.3af, Class 1) and DC input
- Web-based configuration interface and firmware update via Ethernet
- Relay Output for alarm devices



Introduction

The main purpose of managing the status of a machine is to reduce the amount of downtime while also reducing production costs. The easiest way to achieve this is by installing an SL-P6R1-WF/SL-PA6R1-WF intelligent module from ICP DAS, which monitors the output of the machine's indicators without affecting the operation of the equipment, thereby enabling the current operation stage of the machine to be mastered, which ensures timely command of the logistics system support in order to achieve production goals. The SL-P6R1-WF/SL-PA6R1-WF is a stack light monitoring module which includes 6-channel DC/AC Digital Input and 1-channel Relay Output that can be used to monitor the status of the stack lights on the MES (Manufacturing Execution System) machine.

The module can be used to detect the status of each color segment of the stack light to determine whether it is either OFF, ON, or flashing. In addition to detecting the status of each individual color segment, the status for a combination of multiple color segments can also be defined, including the ability to report the duration of the previous status. The SL-P6R1-WF/SL-PA6R1-WF includes WLAN connections that are compliant with the IEEE802.11b/g standards. With the popularity of 802.11 network infrastructure, the SL-P6R1-WF/SL-PA6R1-WF provides an easy method of incorporating wireless connectivity into the monitoring and control of your systems. It is easy to implement stack light status monitoring on an MES via SCADA software, thereby improving machine utilization and throughput. The SL-P6R1-WF/SL-PA6R1-WF also supports the Modbus/TCP and UDP protocols as well as network encryption configuration and offers easy and safe access for users at any time and from anywhere.

Applications

- Factory Automation
- Machine Automation
- Remote Maintenance
- Remote Diagnosis
- Testing Equipment

System Specifications

Model	SL-P6R1-WF	SL-PA6R1-WF
Software		
Built-in Web Server	Yes	
Communication		
RS-485 Port	Baud Rate = 1200 ~ 115200 bps	
Ethernet Port	10/100 Base-TX, 8-Pin RJ-45 x1 (Auto-negotiating, Auto-MDI/MDIX, LED indicators)	
Security	IP filter (whitelist) and Password (web)	
Protocol	Modbus/RTU(RS-485), Modbus TCP(Ethernet, Wi-Fi) and MQTT(Ethernet)	
Dual Watchdog	Yes, Module (2.3 seconds), Communication (Programmable)	
Wi-Fi Interface		
Antenna	5 dBi (OmniDirectional)	
Output Power	8 dBm @ 11 Mbps	
Receive Sensitivity	-83 dBm @ 11 Mbps	
Standard Supported	IEEE 802.11 b/g/n	
Wireless Mode	Infrastructure & Limit-AP	
Encryption	WEP, WPA and WPA2	
Transmission Range	50 meters (LOS)	
LED Indicators		
S1	System indicator	
E1	PoE indicator (Green) Link/Act,(Yellow)	
Antenna	Signal Strength	
Isolation		
Intra-module Isolation, Field-to-Logic	3750 Vdc	
EMS Protection		
ESD (IEC 61000-4-2)	±4 kV Contact for Each Terminal ±8 kV Air for Random Point	
EFT (IEC 61000-4-4)	±2 kV for Power	
Power Requirements		
Reverse Polarity Protection	Yes	
Power Input	Terminal Block: +10 ~ +48 Vdc PoE: IEEE 802.3af, Class 1	
Consumption	PoE	1.2 W Max.
	Non-PoE	1 W Max.
Mechanical		
Dimensions (W x L x H)	33 mm x 108 mm x 127 mm	
Installation	DIN-Rail Mounting	

Environment	
Operating Temperature	-25 to +75°C
Storage Temperature	-30 to +80°C
Humidity	10 to 95% RH, Non-condensing

I/O Specifications

Model	SL-P6R1-WF	SL-PA6R1-WF
Digital Input		
Input Channels	6	
Type	Wet Contact (Sink, Source)	
ON Voltage Level	+10 Vdc ~ 50 Vdc	80 VAC ~240 VAC
OFF Voltage Level	+4 V Max.	30 VAC Max.
Input Impedance	10 KΩ, 0.5 W	150 KΩ, 2 W
Max. Stack Light Flashing Speed	3 kHz	60 Hz
Able to detect the status of each color segment: ON, OFF, or Flashing	Yes	
Status monitoring for user-defined combinations of multiple color segments	Max. 81 combinations	
Report duration of previous status	Yes, 10 ~ 65500 s	
Overvoltage Protection	70 Vdc	300 VAC
Isolation	3750 Vdc	
Digital Output		
Output Channels	1	
Type	Power Relay, Form A (SPST N.O.)	
Operating Voltage Range	250 VAC or 30 VDC	
Max. Load Current	5 A	
Operate Time	6 ms	
Release Time	3 ms	
Electrical Life (Resistive load)	VDE	5 A @ 250 VAC 30,000 ops (10 ops/minute) at 75°C
		5 A @ 30 Vdc 70,000 ops (10 ops/minute) at 75°C
	UL	5 A @ 250 VAC/30 Vdc 6,000 ops 3 A @ 250 VAC/30 Vdc 100,000 ops
Mechanical Life	20,000,000 ops at no load (300 ops/minute)	
Power-on Value	Yes, Programmable	
Safe Value	Yes, Programmable	

Applications

Stack Light Monitoring Solution

Easy to implement stack light status monitoring on an MES to improve machine utilization and throughput.



Pin Assignments

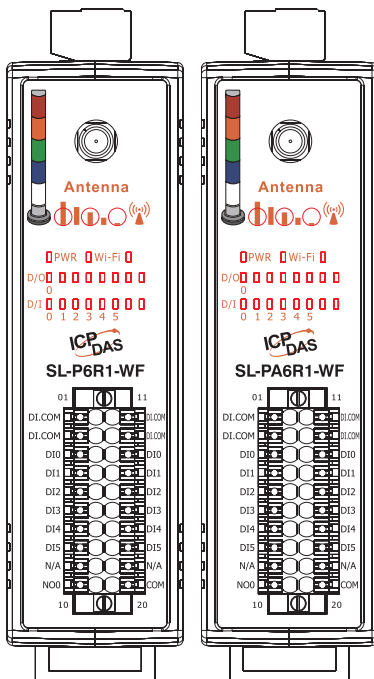

Pin Assignment	Terminal No.	Pin Assignment
DI.COM	01	11 DI.COM
DI.COM	02	12 DI.COM
DI0	03	13 DI0
DI1	04	14 DI1
DI2	05	15 DI2
DI3	06	16 DI3
DI4	07	17 DI4
DI5	08	18 DI5
N/A	09	19 N/A
NO0	10	20 COM

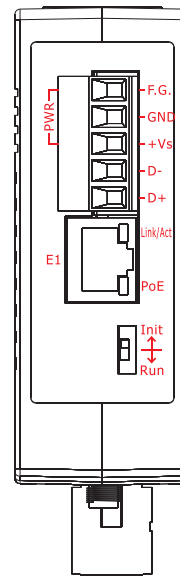

Terminal No.	Pin Assignment
PWR	F.G. GND +Vs
RS-485	D- D+
E1	Init Run

Wire Connections

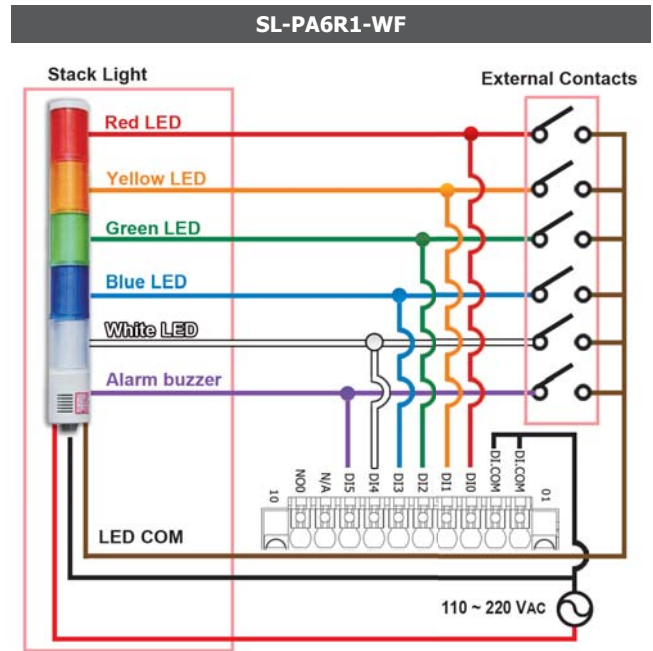
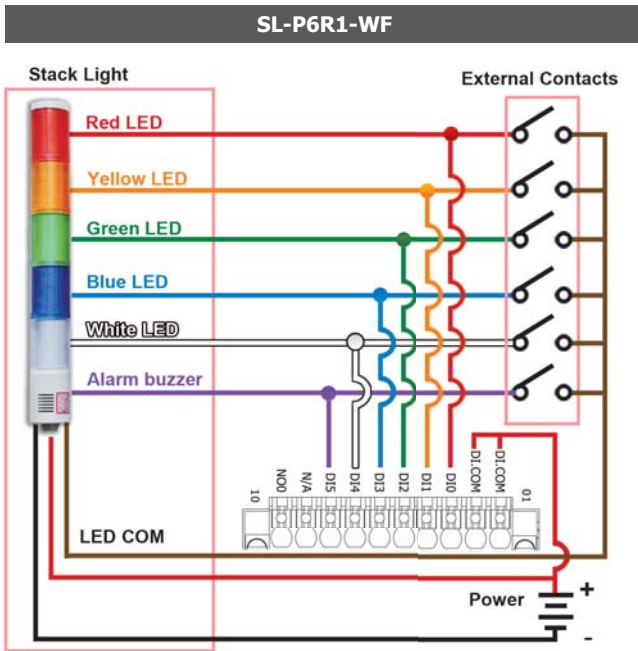
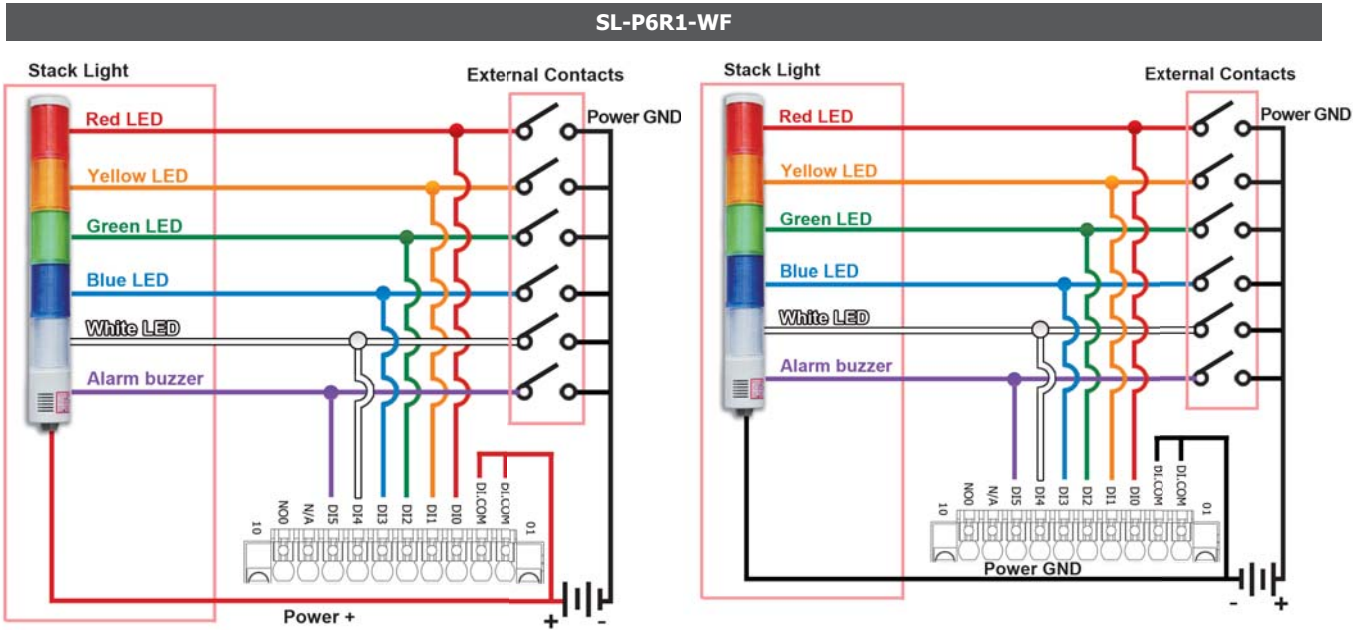

Related Products

	tM-7520U CR Isolated RS-232 to RS-485 Converter (RoHS)
	tM-7561 CR Isolated USB to RS-485 Converter (RoHS)
	I-7514U CR 4-channel RS-485 Hub (RoHS)

	NS-205PSE CR Unmanaged Ethernet Switch with 4 PoE Ports and 1 RJ-45 Uplink (RoHS)
	APW77BAM CR Ethernet to Wi-Fi Bridge (RoHS)
	IOP760AM CR EWi-Fi Access Point (with category A plug type) (RoHS)



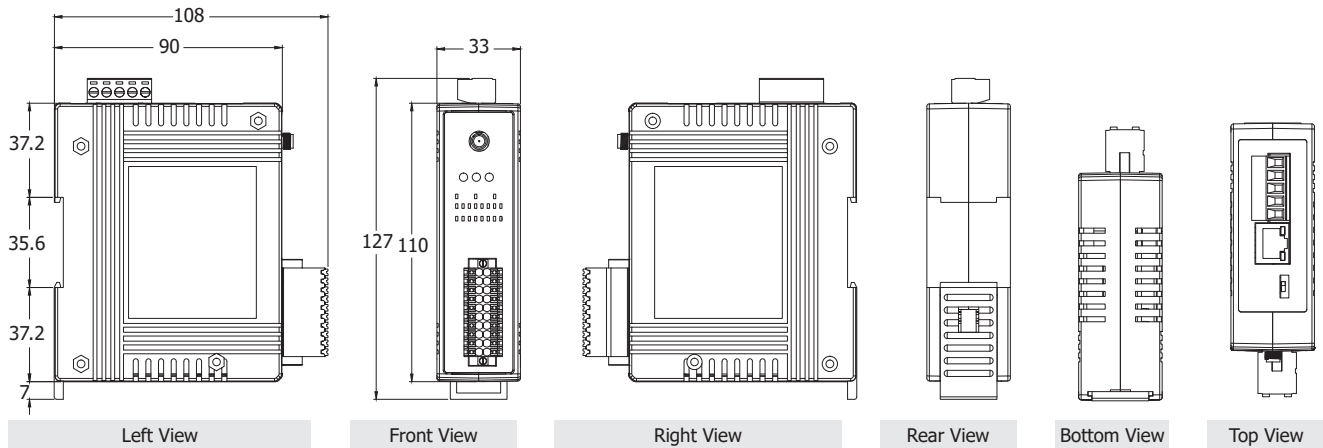

■ Dimensions (Units: mm)







■ Ordering Information

SL-P6R1-WF CR	Single Stack Light Monitoring Module with Ethernet/RS-485/Wi-Fi Interfaces and PoE for DC Stack Lights. (6 DC DI + 1 Relay) (RoHS)
SL-PA6R1-WF CR	Single Stack Light Monitoring Module with Ethernet/RS-485/Wi-Fi Interfaces and PoE for AC Stack Lights. (6 AC DI + 1 Relay) (RoHS)

■ Accessories

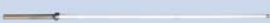
Antenna Extension Cable			
3S001-1 	RG58A/U 1 Meter RP-SMA Male to RP-SMA Female	3S005-1 	RG58A/U 5 Meter RP-SMA Male to RP-SMA Female
3S003-1 	RG58A/U 3 Meter RP-SMA Male to RP-SMA Female	3S008-1 	RG58A/U 8 Meter RP-SMA Male to RP-SMA Female
ANT-Base-02 	Antenna magnetic base with 1.5 meter cable RP-SMA Male Plug		

External Antenna			
ANT-8 	8 dBi 2.4 GHz External Antenna (OmniDirectional)	ANT-18 	18 dBi 2.4 GHz External Antenna (Directional)
ANT-15 	15 dBi 2.4 GHz External Antenna (OmniDirectional)	ANT-21 	21 dBi 2.4 GHz External Antenna (Directional)
ANT-15YG-1 	15 dBi 2.4 GHz External Antenna (Directional)		